

SHAD

HONDA CB 500F / CBR 500R '14

HOCF54iF

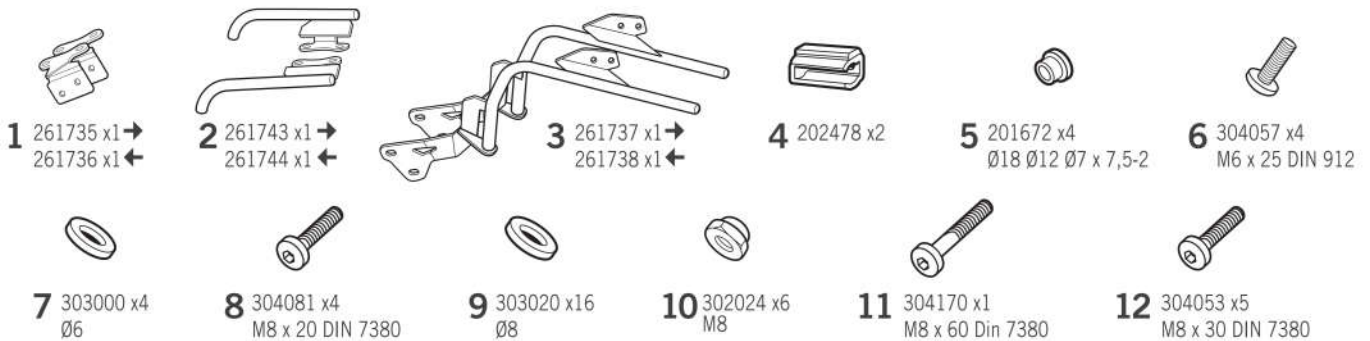

! WARNING!

GB

Do not fully tighten the screws until it is ensured that the KIT is correctly attached and aligned.

E

No apretar los tornillos del todo hasta asegurarse que el KIT está correctamente colocado y alineado.

D

Ziehen Sie die Schrauben nicht ganz fest, bevor Sie sich nicht vergewissert haben, daß der Bausatz korrekt eingestellt und ausgerichtet ist.

I

Non stringere del tutto le viti fin tanto non si è sicuri che il kit è collocato correttamente e allineato.

F

Ne pas serrer les vis avant d'être sûr que le KIT est correctement monté et ajusté.

